

Monitor arms

System 'Oslo'



MONITOR ARM OSLO – FLEXIBLE AND STEADY

A very affordable monitor arm that has become popular for its clean and elegant design. Slim table bracket for mounting in tabletop. It can be supplemented with monitor bar for two monitors, due to the stable design.



(LC15 + LB27 = LC27)



- 438-LC15W □ MONITOR ARM OSLO, WHITE
 - 438-LC15 ■ MONITOR ARM OSLO, SILVER
 - 438-LC15B ■ MONITOR ARM OSLO, BLACK
- ARM LENGTH: 500 MM. TABLE BRACKET 25 MM.
MAX LOAD: 14 KG

- 438-LC27W □ MONITOR ARM OSLO SYSTEM 2, WHITE
 - 438-LC27 ■ MONITOR ARM OSLO SYSTEM 2, SILVER
 - 438-LC27B ■ MONITOR ARM OSLO SYSTEM 2, BLACK
- ARM LENGTH: 500 MM. TABLE BRACKET 25 MM.
MAX LOAD: 2 X 14 KG

- 438-LC29W □ MONITOR ARM OSLO SYSTEM 4, WHITE
 - 438-LC29 ■ MONITOR ARM OSLO SYSTEM 4, SILVER
 - 438-LC29B ■ MONITOR ARM OSLO SYSTEM 4, BLACK
- ARM LENGTH: 500 MM, MAX LOAD: 4 X 9 KG



438-LC65 MONITOR ARM OSLO WITH WALL BRACKET, SILVER
ARM LENGTH: 546 MM

ACCESSORIES

- 438-501W □ TABLE POLE, 400 MM, WHITE
- 438-501A ■ TABLE POLE, 400 MM, SILVER
- 438-501B ■ TABLE POLE, 400 MM, BLACK
- 438-501700W □ TABLE POLE, 700 MM, WHITE
- 438-501700A ■ TABLE POLE, 700 MM, SILVER
- 438-501700B ■ TABLE POLE, 700 MM, BLACK

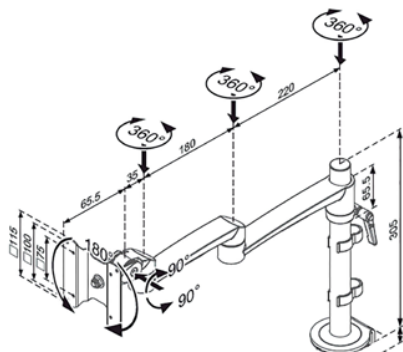

ONLY FOR USE WITH TABLE POLE (501XXX)

- 438-502W □ GROMMET MOUNTING KIT, WHITE
- 438-502A ■ GROMMET MOUNTING KIT, SILVER
- 438-502B ■ GROMMET MOUNTING KIT, BLACK
- 438-601 ■ TABLE CLAMP 10-85 MM, SILVER

- 438-LB27W □ EXTRA MONITOR ARM, WHITE
- 438-LB27 ■ EXTRA MONITOR ARM, SILVER
- 438-LB27B ■ EXTRA MONITOR ARM, BLACK

