

# NOMAD BLOCK<sup>04</sup>

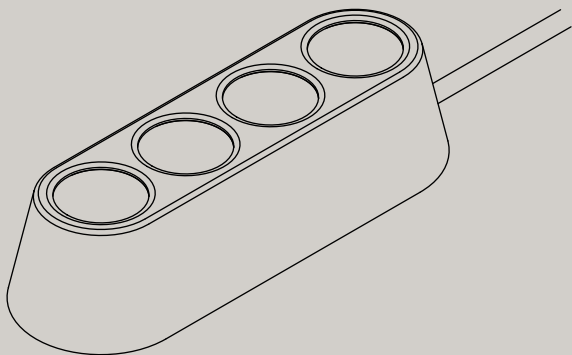

PARTS

---

A ×1 PCE



B ×1 PCE



**GENERAL NOTES**

BEFORE INSTALLATION, ALL MEASUREMENTS AND CONDITIONS MUST BE VERIFIED ON SITE. NEITHER FORMING FUNCTION NOR ANY OF ITS DISTRIBUTORS CAN BE HELD LIABLE FOR PRODUCT MALFUNCTION OR OTHER DEFECTS AS A RESULT OF IMPROPER INSTALLATION.

**GENERAL NOTES**

AVANT L'INSTALLATION, TOUTES LES DIMENSIONS ET CONDITIONS DOIVENT ÊTRE VÉRIFIÉES SUR PLACE. NI FORMING FUNCTION NI SES PARTENAIRES COMMERCIAUX NE PEUVENT ÊTRE TENUS RESPONSABLES DES DÉFAUTS DU PRODUIT OU D'AUTRES DÉFAUTS POUVANT ÊTRE ATTRIBUÉS À UNE MAUVAISE INSTALLATION.

**GENERAL NOTES**

VOR DEM EINBAU SIND ALLE MASSE UND BEDINGUNGEN BAUSEITS ZU PRÜFEN. WEDER FORMING FUNCTION NOCH SEINE VERTRIEBSPARTNER KÖNNEN FÜR PRODUKTFEHLER ODER SONSTIGE MÄNGEL, DIE AUF UNSACHGEMASSE INSTALLATION ZURÜCKZUFÜHREN SIND, HAFTBAR GEMACHT WERDEN

---

**MAGNETIC BOTTOM**

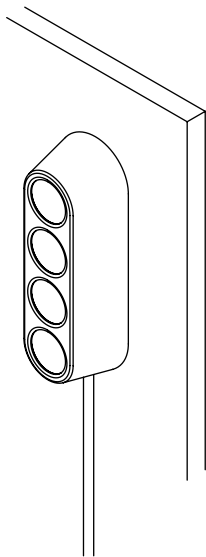

**STEP 1**

Use metal plate for non-magnetic smooth surfaces.

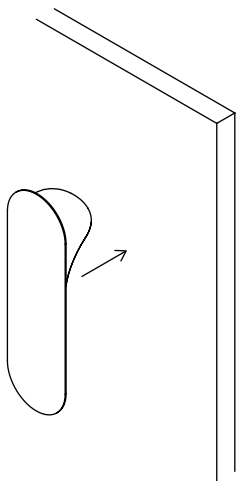

---

**STEP 2**

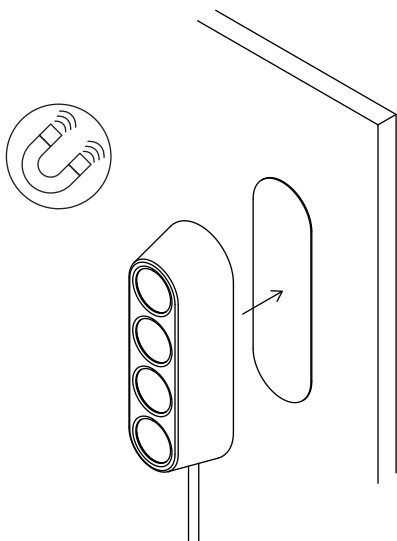

---

**STEP 3**

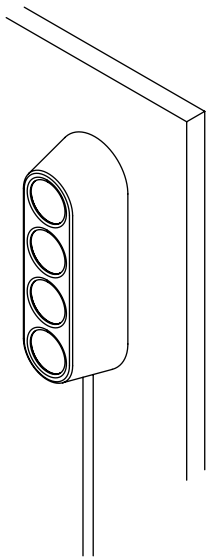

L