

# NOMAD STRIP<sup>05</sup>

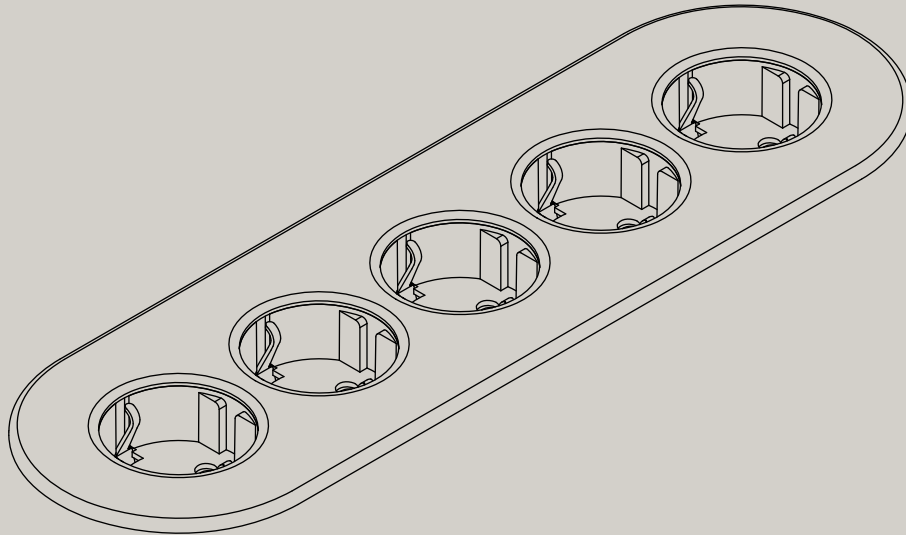

# Product overview

See user manual for assembly instructions

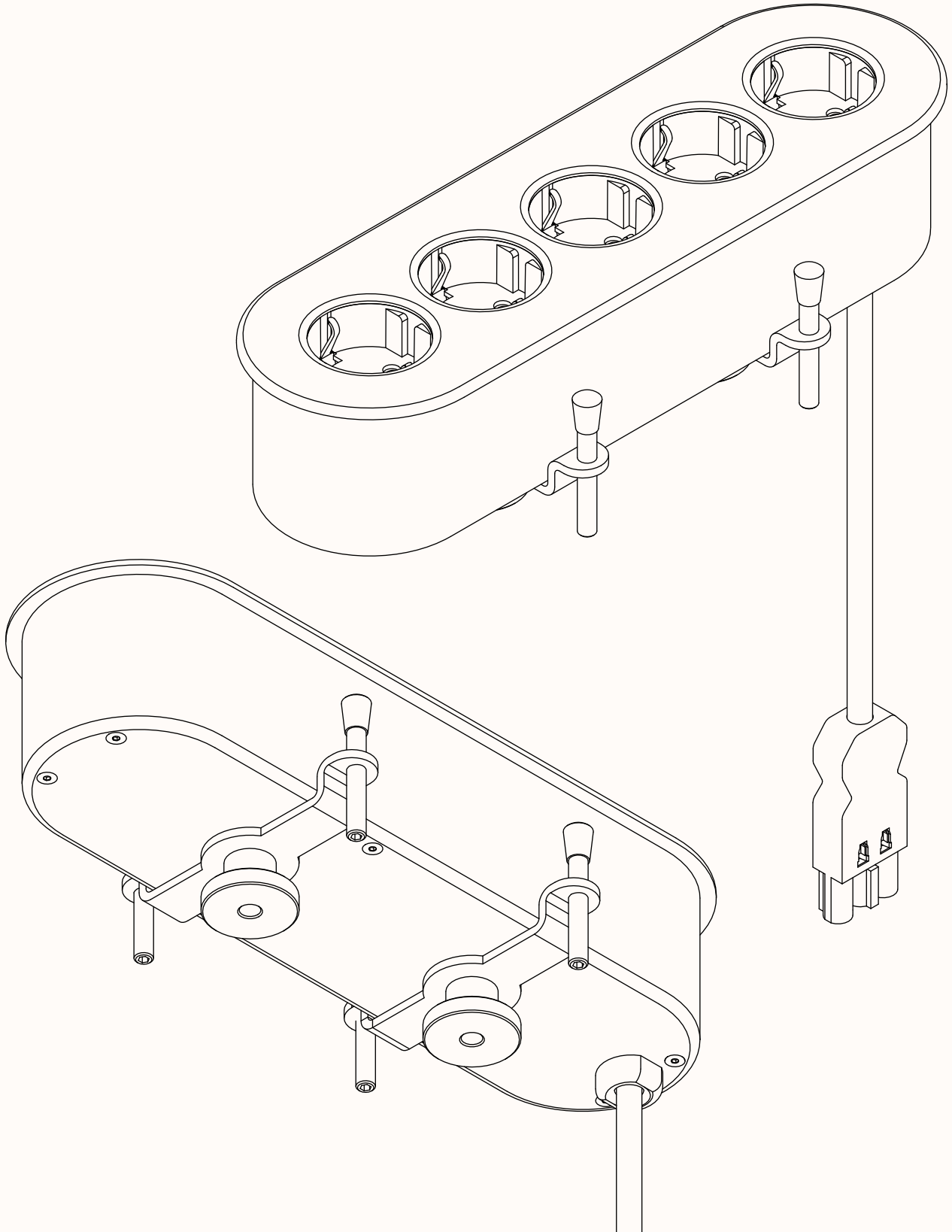

# Product dimensions

See user manual for assembly instructions

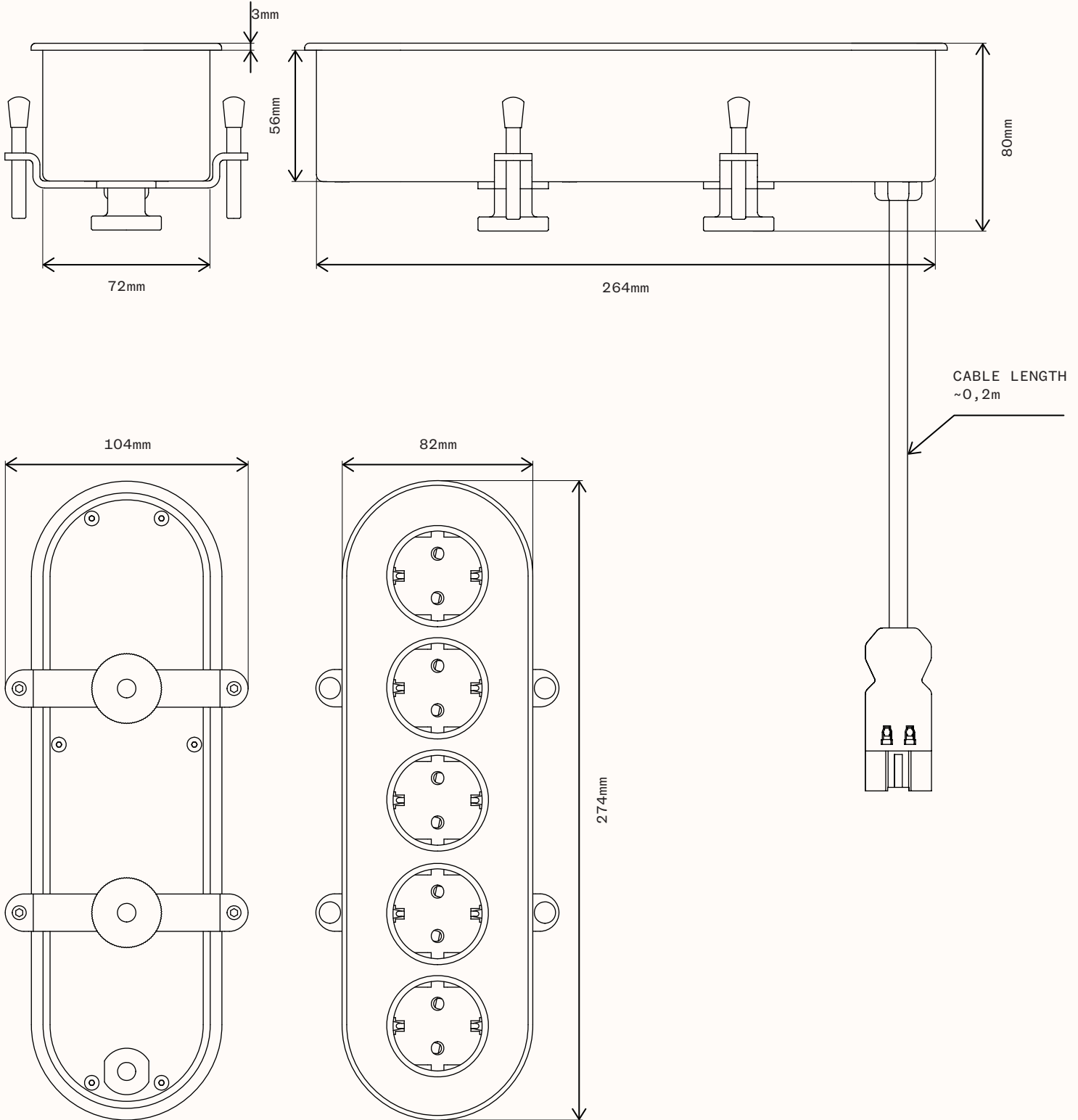

# Table dimensions

See user manual for assembly instructions

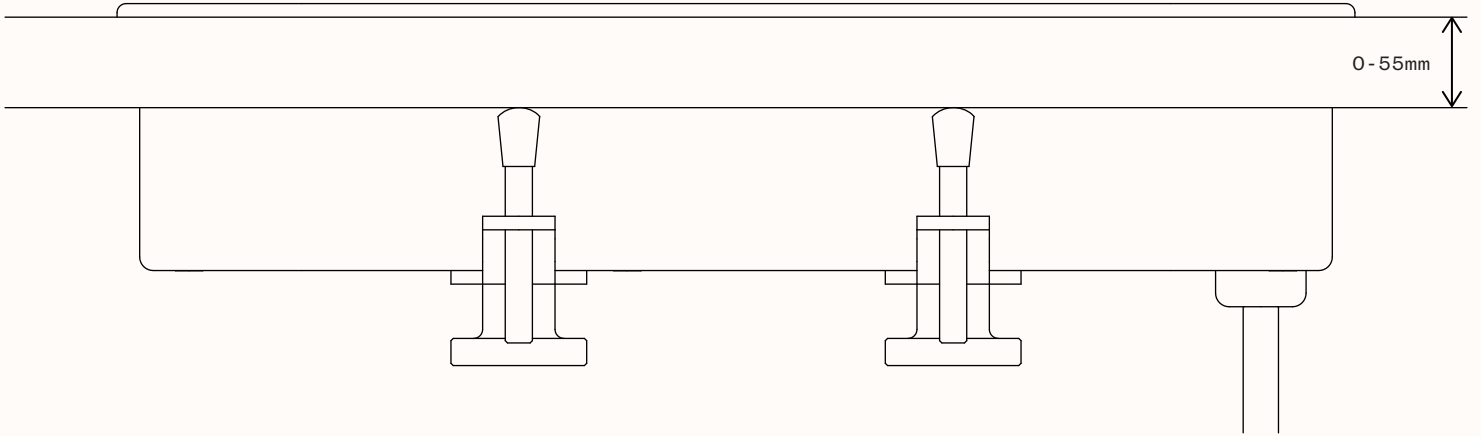

## HOLE CUT DIMENSIONS

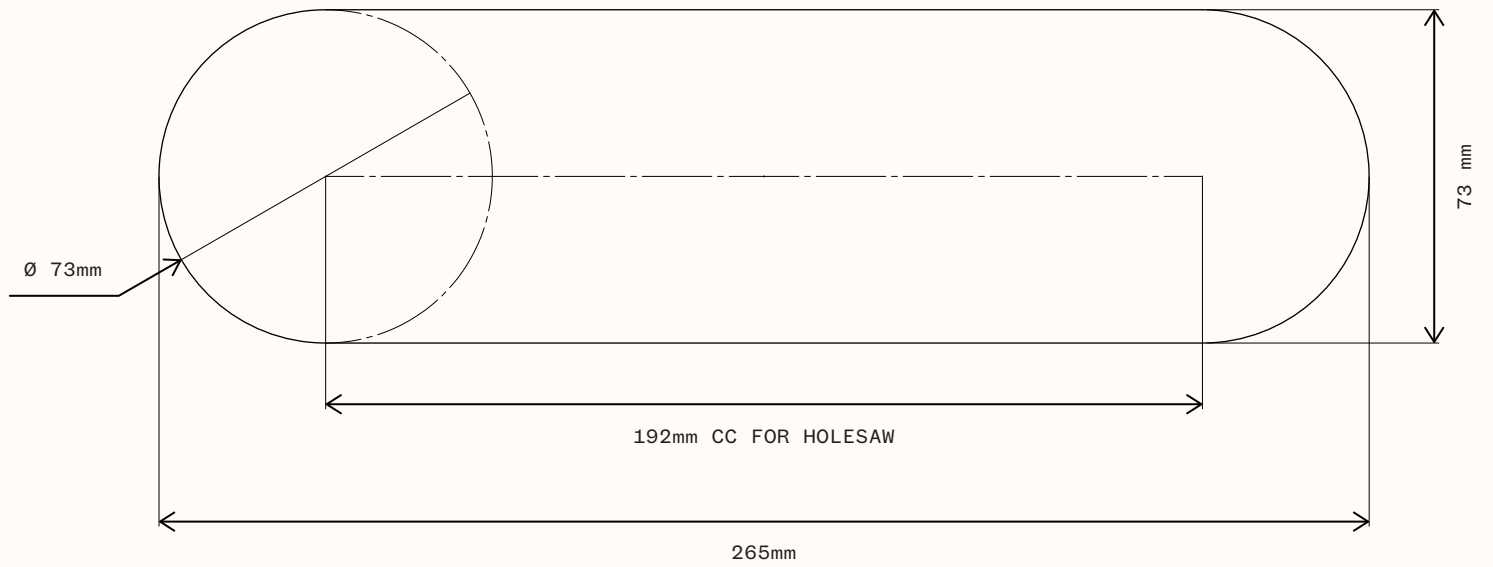

# Colours

---



SIGNAL BLACK  
RAL 9004  
DEEP MATTE, FINE STRUCTURE



WHITE ALUMINIUM GREY  
RAL 9006  
DEEP MATTE, FINE STRUCTURE



STONE CYPRESS GREEN  
RAL 160 50 15  
DEEP MATTE, FINE STRUCTURE

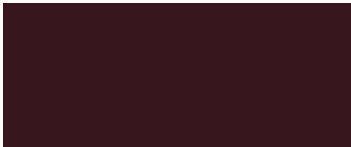

BLACK RED  
RAL 3007  
DEEP MATTE, FINE STRUCTURE

# NOMAD STRIP<sup>05</sup>

5 SOCKET TYPE F, GST18i3

**ART.NO**

9808055109	SIGNAL BLACK	RAL 9004
9808055102	WHITE ALUMINIUM GREY	RAL 9006
9808055105	STONE CYPRESS GREEN	RAL 160 50 15
9808055106	BLACK RED	RAL 3007

## Technical data

---

INTERFACE	5 POWER SOCKETS TYPE F
.....	.....
RATED VOLTAGE	250V
.....	.....
RATED CURRENT	16A
.....	.....
OUTPUT W MAX	3500W
.....	.....
CABLE AND CONNECTOR	3x1,5mm <sup>2</sup> , ~0,2m, GST-18i3 PLUG
.....	.....
MATERIAL OUTER CASING	RECYCLED ALUMINIUM
.....	.....
MATERIAL BOTTOM PLATE AND ENCLOSED ITEMS	STEEL
.....	.....
MATERIAL INNER COMPONENTS	PP AND PA6.6
.....	.....
FINISH	POWDER COATED
.....	.....
PROTECTION CLASS	IP20
.....	.....
MAX TABLE THICKNESS	55mm
.....	.....
CERTIFICATIONS	CE, RoHS COMPLIANT
.....	.....
WARRANTY PERIOD	3 YEARS
.....	.....

# Read before installation and usage

---



Do not cover

Electrical products may only be daisy-chained if integrated into a fixed installation. Normal power sockets may not be used for the connection to further socket rails.



Incorrect installation may endanger:

- Safety of the installer
  - Safety of the end-user and safety of the property.
- Incorrect installation may result in personal liability for damage of property or injury to persons.



Electronic equipment is recyclable and should not be disposed of with household waste, if the device has reached the end of its life, dispose of at the recycling points in accordance with local regulations. Disposal with household waste is prohibited



The device may only be used in a dry indoor environment.

**For safe installation please ensure the following:**

- The 5 safety rules to apply: Disconnect mains; Prevent reconnection; Test for absence of harmful voltages; Ground and short circuits; Cover or close off nearby live parts;
- Choose proper tools, measuring devices and personal protective equipment
- Analyse measured results
- Selection of electrical installation material to ensure switch-off conditions
- IP protection ratings
- Fitting of electrical installation material;
- Type of the feeding system (TN system, IT system, TT system...) and the resulting switching conditions (classic zeroing, protective earthing, necessary additional measures, etc.).



**RoHS**  
Compliant